

THE JAMAICAN

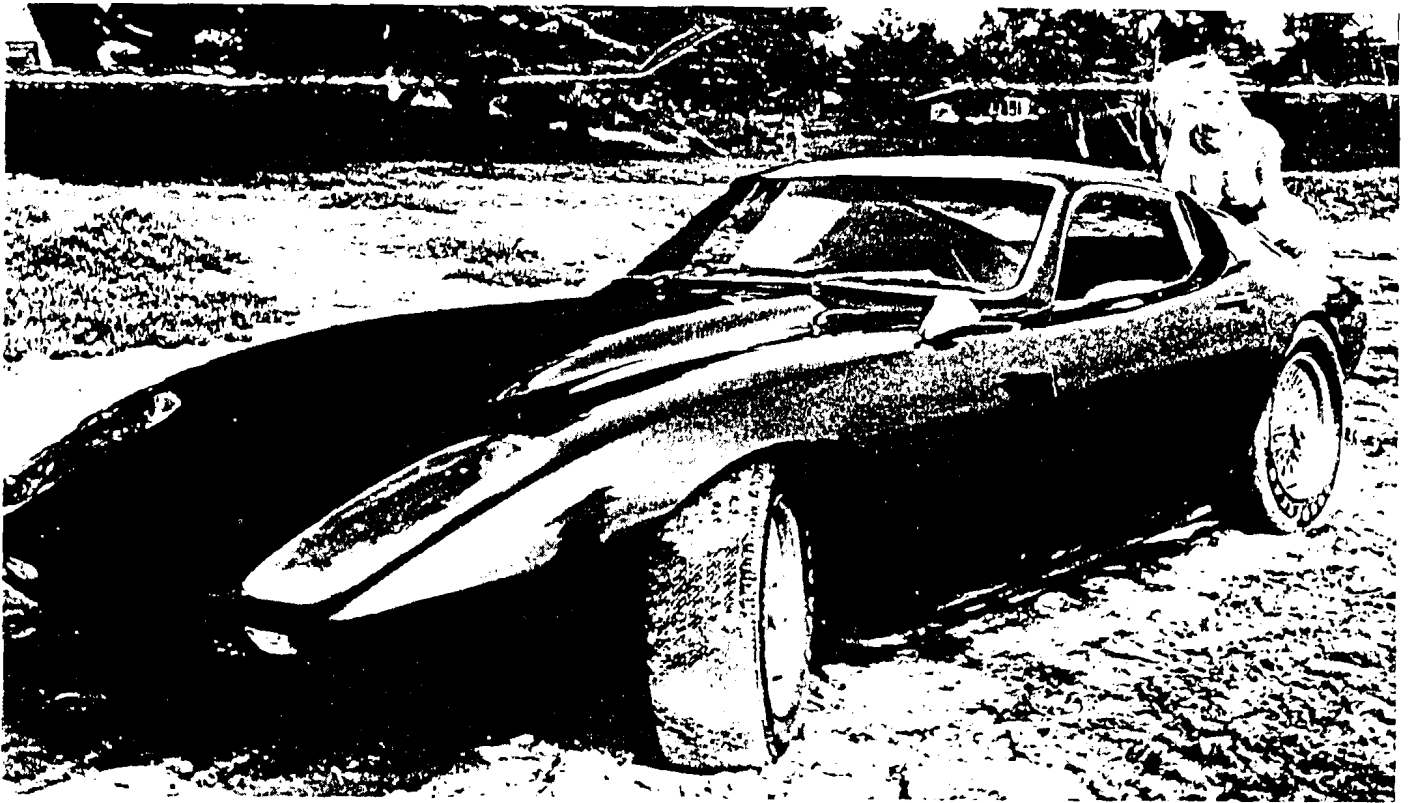

The JAMAICAN is Fiberfab's newest entry in the field of ultra-modern automotive body design. The JAMAICAN is designed to capture in fiberglass the very latest trends in sports and GT Styling — smoother lines; uncluttered, graceful contours; all combined with the look of power.

The JAMAICAN is suitable for use on a number of readily available sports car chassis. The use of the existing metal inner and floor panels of the various chassis, coupled with the built-in paneling of the JAMAICAN body, provides easy installation on the MGA, Austin Healey 4, Austin Healey 6, Triumph TR-3, TR-4 and VW.

The JAMAICAN GT coupe styling crafted in fiberglass gives it tremendous advantages over the

aged rusted-out, leaky bodies it is designed to replace. Comfortable and weathertight, the JAMAICAN is rust and corrosion proof making it a practical as well as a beautiful conversion.

Not only does the design of the JAMAICAN incorporate the ultimate in styling and utmost in comfort it also gives considerable attention to driver safety — all the JAMAICAN window openings are designed to accept readily available automotive safety glass, including roll up side windows, provision for integral roll bar*, reinforced windshield opening.

*Optional—at extra cost.

FIBERFAB

2365 LAFAYETTE
SANTA CLARA, CALIF. 95050



Here are your Jamaican Mounting Instructions. They include all the drawings, parts lists, etc. you will require to complete your car. However, before you peruse the plans let's consider the tools you'll need and a few sources of chassis.

All of our factory cars, like the ones shown in these instructions, are built using no more than the ordinary home workshop inventory of tools. We recommend, as a minimum "Jamaican Workshop", the following:

1. 1/4" electric drill
2. 1/8", 1/4", 3/8" (with 1/4" shank) drill bits
3. One set of woodworking hole saws
4. Keyhole saw or electric saber saw
5. Medium blade standard and phillips screwdriver
6. 3/8", 1/2", 9/16" sockets, wrenches, etc.
7. Straight edge
8. Steel tape
9. Assorted rasps

With regards to the procurement of a chassis -- if you're not already driving it --

We have found the auto wrecking yards to be a good source of chassis--locally we have a directory called a PARTS LOCATOR which lists the various years and makes available throughout our territory. You should check to see if an equivalent guide is available in your locale.



Another source is your insurance agent -- ask him to notify you if he processes any "total wreck" claims involving the chassis - type you're after. Finally, check the classified ads in your local papers under the "auto parts" headings -- many times a usable chassis is listed by an owner before he sells it to a dismantler.

Now on to the details.....

Note: These instructions represent the principal composition of the total Jamaican Mounting Instructions Package. Some very detailed material is withheld and will be sent with your body. In this manner we can always introduce up-to-minute changes into the instructions---changes which occur inevitably as a result of our continuing program of product refinement and improvement.

THE COST OF THESE INSTRUCTIONS
WILL BE REFUNDED ON RECEIPT OF
YOUR FIRST ORDER.



1. CHASSIS

- Required:
 Frame and suspension (incl. hubs)
 Engine (unless considering engine swap)
 Transmission, propellor shaft, rear axle
 Steering assembly, brake system
 Pedal Assembly, (clutch, brake, throttle)
 Some inner panelling (see figure 2)
 Gas tank, Trans. & shaft tunnel covers
 Floor boards (MGA), radiator
- Desirable:
 Original wiring
 Heater
 Instruments
 Wheels and tires

2. JAMAICAN DOOR HARDWARE

- Door Hinges - two sets of hinges are required
- Windows - left and right door windows
- Regulator mechanisms
- Weather stripping - one windlace kit
- Window opening weather stripping
 Weatherstripping chrome trim
 Outside and inside wiper rubber
- Outside wiper chrome trim
- Door Latches - Option 1 (for handleless key only operation): DOOR LATCHES
- Door lock cylinder
 Striker Studs
- Door Latches - Option 2 (with handles)
 Use standard hardware: Latches, handles, and striker studs.

Ford CODB 642 2800A rt. tp.
 Ford CODB 642 2701A lf. tp.
 VW 143 845 201A & 202A
 (glass) 1960-63 Karmann Ghia
 (also 60-63 Karmann Ghia)
 551B, 552B, 571A, 565A
 VW 141 837 501B&502B
 Standard w/upholstery kit or is
 available from Fiberfab
 VW 143 845 211A & 212
 VW 143 853 337A & 338A
 Somaca B-605 (4ea.)
 (61-63 GM cars)
 VW 143 853 516A (2ea.)

Ford C45Z- 6321813-C
 Ford C45Z- 6321812-C
 Ford C50Z-6221984-A1
 Ford C20B-6220008
 Ford C20B-6220009

Karmann Ghia

3. WINDSHIELD

- Safety Glass windshield (included with the Deluxe Kit)
 Rubber Molding
 Chrome Molding and retainor clips

1963-66 Corvette Stingray

Chev. 3844049
 Chev. 3841251 (1ea.)
 Chev. 3841255 (1ea.)
 Chev. 3859044 (2ea.)
 Chev. 3859045 (2ea.)
 Chev. 3843939 (20ea.)

4. REAR WINDOW

- Safety Glass Windshield (included with the Deluxe Kit)
 Rubber Molding
- Chrome Molding

Porsche 901 545 101 20
 Porsche 912 Rear Window
 Porsche 901 545 911 20
 Porsche 901 545 912 20
 Porsche 912 Rear Window
 Porsche 644 541 921 06
 Porsche 912 Rear Window

5. HOOD

Headlights: high beam/low beam combination units (identified by 3-prong connector) with mounting brackets and chrome bulb retaining ring, such as the sealed beam units standard on Austin-Healey, MGA and TR.

Grill: Any grill of your choice fitting an opening measuring 7" x 44" overall. Suggested grill include egg-crate (Camaro), horizontal bar, and expanded metal (available at most hardware stores)

Park/turn indicator lights: select dual-element 12 v bulb units compatible with your grill selection. The lights standard on your chassis will probably suffice.

Hood Latch:

- Option 1: Side Mount
- Option 2: Center Mount

Triumph Spitfire
Austin-Healey or MGA

6. OTHER BODY HARDWARE

Taillights: Any flat panel mounted tail light units of not more than 7" high or 8" wide may be utilized.

License plate light/bracket: Combination holder and light available at most auto supply stores.

Gas tank filler cap: Standard Austin-Healey, MGA or TR cap or chrome flip-top cap available from Fiberfab.

Austin-Healey, MGA, or TR

7. INSTRUMENTS

If the stock gauges are not functioning or are not available, Fiberfab can supply replacements out of the extensive Stewart-Warner line. The following items may be ordered from your local Stewart-Warner dealer or directly from us.....

	<u>STEWART-WARNER NO.</u>
Fuel level gauge	301-AW
Fuel level sender	385-C
Installation kit	366-LP
Water temperature gauge	311-CC
Temperature sender	362-CZ (1/8" P.T.)
	362-AN (1/4" P.T.)
	362-AJ (3/8" P.T.)
	362-AH (1/2" P.T.)
Oil pressure gauge	306-BB
Pressure sender	353-Z
Ammeter	690-J
Speedometer (160 MPH)	530-DH
Other Optional Instruments	
Oil temperature gauge	311-CF
Temperature sender	See Water Temperature
Tachometer	429370
Tachometer sender	429375 (6 cyl.)
	429377 (4 cyl.)



FIBERFAB, INC

548 Baldwin Street
Bridgeville, Pennsylvania 15017
Phone 412 221-6200

JAMAICAN SERIES PRICE LIST

JAMAICAN SERIES BASIC BODY KITS:

EFFECTIVE 7/1/76

JAMAICAN I	BASIC BODY KITS FOR TR3, TR4, TR4A, TR6, TR250, MGA, AUSTIN HEALEY 3000.	\$1595.00
JAMAICAN II	BASIC BODY KIT FOR VW OR KARMANN GHIA.	\$1795.00
JAMAICAN II-V8	FRAME* AND BASIC BODY KIT FOR FRONT MOUNTED V8.	\$2700.00

*THE JAMAICAN II-V8 FRAME KIT IS A SUPER SOPHISTICATED INDEPENDENT SUSPENSION AND POWER TRAIN. THE JAMAICAN II-V8 FRAME IS A LADDER FRAME CONSTRUCTED OF 5" X 2" X .120 STEEL TUBING, HELIARC WELDED TOGETHER IN A STABILIZING JIG. A SPECIAL FLOORPAN IN THE JAMAICAN II-V8 BODY LOCKS THE BODY IN PLACE ON THE FRAME. THE FRAME IS ENGINEERED TO ACCEPT A SMALL BLOCK CHEVY V8 FORWARD MOUNTED, COUPLED TO A COMPATIBLE STANDARD OR AUTOMATIC TRANSMISSION. THE FRONT SUSPENSION IS CORVAIR ('66 OR NEWER), THE THIRD MEMBER IS CORVETTE ('63 OR NEWER), AND THE REAR SUSPENSION IS CORVAIR ('66 OR NEWER). CORVAIR RECIRCULATING BALL TYPE OR PINTO RACK & PINION TYPE STEERING MAY BE USED. THE NEWEST JAMAICAN II-V8 KIT UTILIZES THE CAMARO FRONT SUBFRAME AND THE CHEVELLE REAR AXLE ASSEMBLY.

JAMAICAN SERIES BASIC BODY KITS INCLUDE:

1. MAIN BODY WITH INNER PANELS.
2. FORWARD NOSE SECTION (ONE-PIECE TILT CONFIGURATION) FOR JAMAICAN I KITS ONLY. FORWARD NOSE SECTION AND SEPARATE HOOD FOR JAMAICAN II AND II-V8 KITS ONLY.
3. ENGINE ACCESS/TRUNK LID FOR JAMAICAN II AND II-V8 KITS ONLY.
4. ONE PAIR DOORS.
5. ONE PAIR FIBERGLASS GT SEAT SHELLS (NOT UPHOLSTERED). EASY RIDER SEAT SHELLS WITH HEADREST ARE OPTIONAL AND \$30.00 ADDITIONAL.
6. ONE DASH PIECE.
7. FRAME KIT FOR JAMAICAN II-V8 KIT ONLY.
8. ONE FIBERGLASS TRANSMISSION CONSOLE-COVER FOR JAMAICAN II-V8 KIT ONLY.
9. ASSEMBLY MANUAL. (MAY BE ORDERED IN ADVANCE FOR \$10.00.) SPECIFY CHASSIS.

JAMAICAN SERIES OPTIONS:

VDO COCKPIT GAUGES 12 VOLT ONLY:	SPEEDOMETER	\$ 58.50
	TACHOMETER	58.50
	AMMETER	13.91
	FUEL GAUGE	20.26
	OIL TEMPERATURE GAUGE	22.80
	OIL TEMPERATURE SENDER	9.46
	VDO COCKPIT GAUGES FOR JAMAICAN II-V8 ONLY:	SPEEDOMETER
TACHOMETER		74.89
AMMETER		17.72
FUEL GAUGE		25.72
OIL PRESSURE GAUGE		21.53
OIL PRESSURE SENDER		18.99
WATER TEMPERATURE GAUGE		22.80
WATER TEMPERATURE SENDER	7.65	
INTERIOR UPHOLSTERY, BLACK ONLY.		250.00
GT SEAT COVERS, BLACK ONLY, PAIR.		89.95
EASY RIDER SEAT COVERS, BLACK ONLY, PAIR.		119.95

THE JAMAICAN SERIES BODY KITS ARE NOW OFFERED IN PRE-ASSEMBLED FORM. THE BODY IS TOTALLY ASSEMBLED. JUST MOUNT TO YOUR CHASSIS. COMPUTE FROM PRICE LIST ITEMS DES'RD.

ADD LABOR CHARGE OF \$1200.00 FOR JAMAICAN I AND II KITS, \$1500.00 FOR JAMAICAN II-V8 KIT.

JAMAICAN SERIES DELUXE PAK (OPTIONAL ITEMS):

WINDSHIELD GLASS	CORVETTE '63-'67	1 REQ.	\$ 98.00 EA.
WINDSHIELD REVEAL MOLDING	CORVETTE '64-'67	1 REQ.	35.94 EA.
WINDSHIELD POLY TAPE		1 REQ.	9.00 EA.
WINDSHIELD REVEAL CLIPS		1 SET	2.00 EA.
REAR GLASS CLEAR	PORSCHE 911-912	1 REQ.	146.25 EA.
REAR GLASS GASKET		1 REQ.	35.63 EA.
REAR GLASS REVEAL MOLDING		1 REQ.	47.50 EA.
SIDE GLASS	KARMANN GHIA HARDTOP '61-'74	2 REQ.	44.00 EA.
SIDE GLASS CARRIER CHANNEL	KARMANN GHIA HARDTOP '61-'74	2 REQ.	5.00 EA.
SIDE GLASS CARRIER GASKET	KARMANN GHIA HARDTOP '61-'74	2 REQ.	2.00 EA.
SIDE GLASS REGULATOR	KARMANN GHIA HARDTOP '61-'74	2 REQ.	28.00 EA.
SIDE GLASS WINDOW GUIDE TRACK	KARMANN GHIA HARDTOP '61-'74	2 REQ.	29.10 EA.
SIDE GLASS MOLDING EXTRUSION		2 REQ.	7.40 EA.
SIDE GLASS MOLDING EXTRUSION WEATHERSTRIP		2 REQ.	9.40 EA.
SIDE GLASS WEATHERSTRIP INNER		2 REQ.	5.25 EA.
SIDE GLASS WEATHERSTRIP OUTER		2 REQ.	6.25 EA.
DOOR HINGES LEFT	MUSTANG '65-'67 OR PINTO	1 SET	19.95 EA.
DOOR HINGES RIGHT	MUSTANG '65-'67 OR PINTO	1 SET	19.95 EA.
OUTSIDE BAT HANDLE, LATCH & CABLE ACTUATOR		2 REQ.	21.56 EA.
WINDLACE - DOORWAY SURROUND		2 REQ.	15.00 EA.
HEADLIGHT		2 REQ.	24.30 EA.
FRONT TURN SIGNAL		2 REQ.	5.67 EA.
TAIL LIGHT		2 REQ.	23.20 EA.
INDICATOR DASH LIGHT		3 REQ.	2.67 EA.
CHROME GAS CAP COVER		1 REQ.	11.01 EA.
DIMMER SWITCH		1 REQ.	2.74 EA.
ST BAT HANDLE SWITCH		2 REQ.	3.97 EA.
IGNITION SWITCH WITH KEYS		1 REQ.	8.00 EA.
HEADLIGHT BAT HANDLE SWITCH		1 REQ.	3.97 EA.
INSIDE REAR VIEW MIRROR		1 REQ.	10.58 EA.
WALNUT STEERING WHEEL		1 REQ.	39.95 EA.
WIRING HARNESS		1 REQ.	45.00 EA.
DEFOGGER - DEFROSTER		1 REQ.	39.50 EA.
FENDER MOUNT MIRROR - BLACK PRIMED		2 REQ.	9.02 EA.
DOOR LATCH HANDLE INSIDE, EUROPEAN STYLE		2 REQ.	6.65 EA.
DOOR WINDOW HANDLE INSIDE, EUROPEAN STYLE		2 REQ.	7.35 EA.
WINDSHIELD WIPER ASSEMBLY, COMPLETE WITH ARMS & BLADES		1 REQ.	89.95 EA.

JAMAICAN SERIES ACCESSORIES:

OIL PRESSURE GAUGE 70#	\$20.26
OIL PRESSURE GAUGE SENDER	18.99
FUEL TANK FLOAT UNIT	15.88
QUARTZ CLOCK	50.74
FOUR-WAY FLASHERS	15.17
LICENSE PLATE BRACKET AND LIGHT	12.00
CONSOLE	25.34
ROADRUNNER STEERING WHEEL - EUROPEAN STYLING FOAM	29.95
FORMULA GT STEERING WHEEL - LEATHER COVERED	49.95
SEAT ADJUSTERS, 5" TRAVEL, PAIR	14.00
QUICKSHIFT KIT	4.40
CUSTOM SHIFTER '68-'74 VW	9.90
CUSTOM SHIFTER '56-'67 VW	11.90
PEDAL AND ACCELERATOR COVER KIT	9.90
OIL COOLER AND FILTER UNIT	48.57
HIGH PERFORMANCE AIR CLEANER	9.30
FENDER MOUNT MIRROR - CHROME	9.23
HEADLIGHT COVERS, PAIR	39.98
GT STYLE FRONT BUMPER	49.95
GT STYLE REAR BUMPER	49.95
HEADER/DUAL MUFFLER COMBINATION	62.95
DECALS, BLACK LETTERING, PAIR	9.95
MEDALLION, ROUND PEWTER	9.95

CURB WEIGHT: JAMAICAN I, 1600#, JAMAICAN II, 1475#, JAMAICAN II-V8, 2100#.

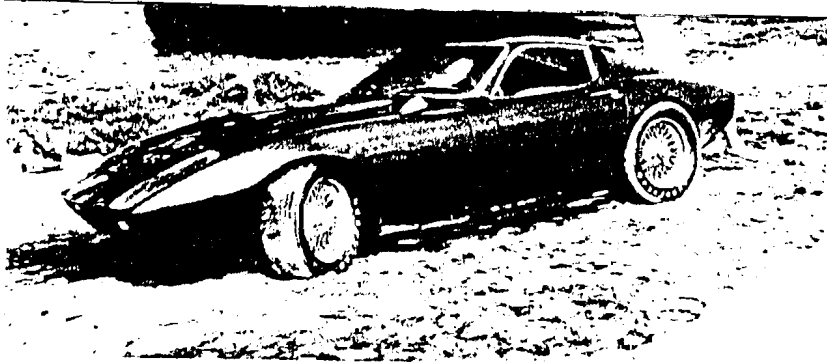

KIT #1 — STANDARD JAMAICAN KIT INCLUDES:

- | | |
|---|--|
| 1) JAMAICAN body | 7) Wide, fully flanged doorsills |
| 2) Front hood hinges (prelaminated into body) | 8) Rear window surround flange |
| 3) Complete inner panels (to mount body) | 9) Windshield surround flange |
| 4) Headlight indents | 10) Metal reinforcing inside windshield area |
| 5) Dashboard | 11) Side and front air scoops |
| 6) Recessed license plate holder | 12) Mounting instruction booklet |

KIT #2 — DELUXE JAMAICAN KIT, includes everything in KIT #1, PLUS:

- | | |
|--|---|
| 1) Safety glass windshield | 3) Rear safety glass window |
| 2) Door-inner panels for roll-up mechanism | 4) Choice of GT, Classic or Lotus-type fiberglass seat shells |

Complete mounting and chassis preparation instructions are included with each body order. Should you wish a copy prior to purchasing your body, the mounting booklet is available for \$5.00 refundable with order.

JAMAICAN PRICE LIST

JAMAICAN Kit #1, Standard	\$795.00
JAMAICAN Kit #2, Deluxe	895.00
JAMAICAN Deluxe Upholstery Kit (BIK)	195.00
JAMAICAN Plexiglass Headlight Covers	30.00

The following accessories included with the Deluxe Kit are also available separately:

JAMAICAN Safety Glass Windshield	45.00
JAMAICAN Safety Glass Rear Window	55.00

TABLE OF CONTENTS

1. CONSTRUCTION MATERIALS -- Tools and Supplies
2. WHAT TO LOOK FOR WHEN ACQUIRING A WRECKED VEHICLE: MG, TR, AUSTIN HEALEY
3. PREPARING THE CHASSIS -- What goes? What stays?
4. MOUNTING THE JAMAICAN BODY
5. INSTALLING THE WINDOWS AND WINDSHIELD
6. WIRING AND INSTRUMENTS
7. UPHOLSTERY -- Interior Finish
8. SANDING, PRIMING AND PAINTING -- Exterior Finish
9. V-8 POWER OPTION
10. JAMAICAN/VOLKSWAGEN

INTRODUCTION

The following pages contain instructions for assembling the 1968 JAMAICAN. These instructions are intended to cover every phase of preparation, assembly and finishing required to bring your car - building project to a successful conclusion.

To meet the demands of the many people who prefer the driving "feel" and external appearance of a front-engined sports car, Fiberfab created the JAMAICAN.

During the development of the JAMAICAN design, it was realized that certain unibody cars such as the Austin-Healey Sprite and MGB were not suitable vehicles for a "body swap". In other words, removal of the original metal body removed too much structural rigidity. Nevertheless, elimination of the unibody cars still left three very popular front-engined sports cars to be considered -----
AUSTIN-HEALEY, MGA, and TRIUMPH.

When you order your JAMAICAN kit, you can specify the chassis on which you plan to mount it, so that when your JAMAICAN body is produced, the proper inner panels for mounting are laminated into the body--thus the body fits precisely on just the type of car you are converting.

1. CONSTRUCTION MATERIALS

The typical inventory of tools found in most home garages or basements will probably more than suffice to complete your JAMAICAN. In reality, very few tools are absolutely essential to the conversion.

The following breakdown of tools is based on Fiberfab factory experience. Items that are considered essential are listed. Another list is also provided of items which are quite helpful and serve to make certain construction tasks significantly easier.

HAND TOOLS

Essential

- 5/16", 3/8", 7/16", 1/2", 9/16", 5/8" sockets -- 3/8" Drive
- 3/8" Drive Ratchet Handle
- Standard screw-driver -- medium blade
- Phillips screw-driver -- medium blade
- Straight-edge

Helpful

- 3/8" Drive -- 3" and (6") extensions
- 3/8", 7/16", 1/2", 9/16" combination (open-end and box-end wrenches)
- "Pop" rivet gun -- home workshop variety
- Steel rule (72")
- Wire-terminal crimping tool
- Hacksaw
- Knife
- Assorted rasps, files, drills and taps
- Set of wood-working hole-saws

POWER TOOLS

Essential

- Electric drill -- 1/4" capacity

Helpful

- Electric drill -- 1/2" capacity
- Sabre saw
- Rotary sander/grinder
- Hydraulic floor-jack and jack stands

CONSTRUCTION MATERIALS

Essential

- Assorted machine bolts and nuts; 1/4", 5/16" and 3/8"; with washers and locking washers
- Assorted sheet metal screws
- Sandpaper
- Silicone seal (common types are Rubber Sealant by the Macklenburg-Duncan Company of Oklahoma City, Dow-Corning DC 750, and General Electric)
- Butyl tape (windshield installation kit) -- typical is Somaca #9103*
- 200'-300' #26 AWG wire; 100'-150' #10 AWG wire (if chassis re-wiring required)
- Primer, paint, etc.
- Car seam sealer, 1 tube -- typical is 3M* #1915-5209

Helpful

- Epoxy adhesive kit (high-grade epoxy, not body filler type)
- Epoxy putty/filler
- Crimp-on wire terminals
- Assorted "pop" rivets

* Somaca-Western, 852 Aldo Ave., Santa Clara, Calif. SOMMER AND MACA, 5501 W. Ogden Ave., Chicago, Illinois

* 3M is the trademark of Minnesota Mining and Manufacturing

2. WHAT TO LOOK FOR WHEN ACQUIRING A WRECKED VEHICLE

Many persons purchasing a JAMAICAN body wish to replace the travelworn or weathered "skin" of the vehicle they already own and are currently driving. Other builders plan to acquire a wrecked Austin Healey, MGA or TR from a salvage yard and refurbish this "outcast" with a new JAMAICAN body and perhaps some new mechanical parts. In either instance, this brief section should be of interest to all prospective builders.

In most areas of the United States, at least three approaches to obtaining a suitable, salvageable sports car are available. The first approach is to contact the local dealer in the vehicle of interest. He may have been asked to bid on insurance work and will know the availability and location of wrecked vehicles. The second approach is to call several automobile insurance companies and ask about any recent wrecks they have declared to be "totals" -- many times if the car is earlier than 1960 and the body damage is moderate to extensive, the car will be "totalled" even though under its rumpled skin is a mechanical "jewel".

The third and most obvious approach is to call the local salvage/wrecking yards -- especially those advertising a foreign car section. Some areas of the U.S.; for example, the San Francisco Bay Area where Fiberfab is located; have publications appearing weekly or monthly which list all wrecked vehicles and their location. The publication we use is:

THE PARTS LOCATOR
1696 Washington Avenue
San Leandro, California

Information concerning similar publications in other localities may be forthcoming from the above address, upon request.

When a seemingly suitable wreck is finally located, look it over closely in person, not via photographs. Don't let a mangled body dismay you or a clean-looking body fool you. Remember, you are interested primarily in the frame, drive-line, suspension and engine -- broken doors, ripped seats, shattered glass, etc., are of not consequence.

Items to be checked are:

1. CONDITION OF ENGINE -- valve cover not crushed, carburetors intact, exhaust manifold not torn loose, pan secure and not leaking, radiator free of punctures, etc. -- try to get some kind of guarantee that the engine is in running condition.
2. CONDITION OF SUSPENSION -- all axles rotate, steering linkage is not bent or broken, A-frames (front suspension) unbent, etc.
3. CONDITION OF DRIVE-LINE -- with one rear wheel blocked from rotating, make sure the other rear wheel turns reasonable freely when the gearbox is in neutral and does not turn at all when any gear is selected (assuming, of course, that an engine is in place in the vehicle).
4. CONDITION OF THE FRAME -- using a steel tape, measure the squareness of the frame; i.e., check fore and aft dimension between the wheel centers on both sides (the "wheelbase") -- are they identical? Look under the car and assure yourself that none of the frame members are crushed or bent.

In addition, try to get as many pieces of auxiliary equipment as possible at the time you buy the "outcast" --- items such as windshield wiper motors, instruments, etc., will probably be cheaper in a "package deal" than if you return later to purchase them separately.

As an aid to acquiring a usable wreck and estimating its worth, some vital statistics are presented below:

AUSTIN-HEALEY

The Austin Motor Company of Birmingham, England started building the Austin-Healey 100 sports car in 1952. The Austin-Healey 100 used the 2.6 liter, four-cylinder Austin A90 engine. Subsequent versions were the 100M and 100S; both aimed at competition events. The 100S engine developed 132 BHP and had disc brakes.

Next in the Austin-Healey evolution was the 100-6 using a BMC, 2.6 liter, six cylinder engine. Some of the 100-6 models were produced with a six-port head to obtain higher performance than the standard 100-6 engine output of 102 BHP. In 1959, a 3 liter six cylinder engine was introduced in the Austin-Healey 3000. The 3 liter engine was available for a brief period (1961-1962) in a 3-carburetor version which proved quite difficult to keep in tune. The Austin-Healey 3000 had disc brakes (front) and wire wheel options. The wheelbase is 92 inches.

MG

As early as 1936, the MG Company (now located at Abingdon, England), produced a vehicle suitable for conversion with a JAMAICAN body -- the MG, TA. This car featured a 1.3 liter, 50 BHP, four cylinder engine. In April, 1939 the TA was replaced by a new model with minor refinements, the MG TB. The total TA and TB production, before it was discontinued as a result of WWII, was only 3400 cars.

Shortly after the war, the TB was revived in a new form as the MG TC which was soon followed by the TD. Both were equipped with 57.5 BHP engines. In 1954 the 63 BHP TF 1500 was introduced but was short-lived because in 1955 production was commenced on the MGA which offered a 78 BHP engine. The MGA series offered several interesting options -- disc brakes (front), wire wheels and a twin overhead cam engine in place of the standard pushrod engine.

In 1962, the MGB arrived on the scene, but as previously mentioned, its unibody construction precludes its use as a vehicle for the JAMAICAN. All of the cars listed above, except the MGB, will accept the JAMAICAN body inasmuch as they all have frames separable from the bodywork and they all have 94" wheelbases.

Market response for the JAMAICAN has revealed, however, that 99% of the buyers using the body on MGs were using a MGA. Therefore, the JAMAICAN is inner-paneled to fit the MGA series exactly although the body can be used with the MG TA, TB, TC, TD or TF.

TRIUMPH

In 1952 when Standard took over the Triumph Company to form the Standard-Triumph Motor Company, the Standard Vanguard engine was modified to 2 liters developing 100 BHP and fitted to a Triumph Mayflower chassis to create the TR2 sports car. Since 1952 the TR2 has evolved through the TR3 to the TR4 and currently the TR4A with independent rear suspension. All these cars have been fitted with front wheel disc brakes and all have an 88" wheelbase.

The inner-paneling for the JAMAICAN-for-Triumph has been designed to fit all TR's with two basic models -- one for TR3 and TR2 and one for TR4, TR4A, TR4A-IRS, and TR 250. Therefore, when a JAMAICAN-for-Triumph is ordered the model must be stated.

3. PREPARING THE CHASSIS

The first step in the building of your new JAMAICAN is to prepare the chassis for the JAMAICAN body. The following tasks to be completed are common for all vehicle types.

1. Remove the battery.
2. Drain the gas tank.
3. Remove gas tank filler hose and cap assembly, and tape shut filler neck with masking tape.
4. Remove seats and all upholstery.
5. Remove windshield and wiper arms.
6. Remove doors.
7. Remove spare tire.
8. Remove hood-cover engine with tarpaulin or equivalent.
9. Remove deck lid.
10. Disconnect all wiring to lights and fuel tank, and protectively tape the wire-ends.
11. Remove headlights and park/turn lights.
12. Remove license light-bracket.
13. Remove windshield wiper motor and mechanism.
14. Remove bumpers.
15. Remove fenders (most bolts are located inside wheel wells).
16. Drain engine and radiator of water.
17. Remove radiator.
18. Remove instruments and panel controls and protectively tape the wire-ends.

For the next steps, turn to the section describing your particular chassis.

AUSTIN-HEALEY

1. Un-bolt relay, fuse block, volt regulator, etc., from firewall and place them down out of the way.
2. Remove gas tank.
3. Remove front bumper brackets and horns.
4. Cut off outer skin at fender line.
5. Referring to Figure 2A* :
 - a. Remove rear cross braces (between fender inner panels).
 - b. Remove rear fender inner panels (down to chassis).
 - c. Remove cowl brace (stamped sheetmetal).
 - d. Remove lower door sills and front hinge posts (see detail for cutting side panels).
 - e. Cut 2" off top of firewall.
 - f. Remove body mount brackets and cross brace from front wheel wells.
 - g. Trim 4" off of outside of wheel wells, parallel with center seams.
6. Remove mounting brackets from radiator and replace 2" higher on radiator.
7. While holding radiator in place on chassis, mark section of frame cross member that interferes with lower hose outlet. Cut this section out of cross member.
8. Bolt radiator in its new position.
9. Trim off all protrusions on inside (cockpit side) of firewall above heater duct.

MGA

1. Un-bolt relay, fuse block, volt regulator, etc., from firewall and place them down out of the way.
2. Remove heater assembly including defrosters. (The blower side of the heater box will have to be dropped 1-1/4 inches. This is easily done by dis-assembling the box, cutting a wedge out of the side panels, bending new tabs and re-assembling the box.)
3. Remove outer skin at fender line.
4. Remove cowl support bracket.
5. Referring to Figure 2B* :
 - a. Cut front wheel well panels just ahead of radiator mounting flanges.
 - b. Un-bolt front bumper support brackets.
 - c. Remove nose section.
 - d. Remove door sills, and rocker panels.
 - e. Cut side panels (with hinge posts) straight down 2" back from upper firewall (vertical surface where relay, fuse block etc., were attached).
 - f. Remove rear fender inner panel cross brace.
 - g. Remove rear fender inner panels down to inner floor surfaces.
 - h. Cut upper firewall straight across from fender panel-to-fender-panel, and trim off all protrusions from inside of remaining panel.
 - i. Fabricate radiator mounting flange extensions so that radiator can be mounted down 2" and forward enough to clear lower hose.

*HEREINAFTER AN ASTERISK FOLLOWING A FIGURE NUMBER REFERS TO THE BLUEPRINTS.

TR3 - TR4

1. Remove gas tank.
2. Remove outer skin.
3. Remove all hardware from upper firewall.
4. Referring to Figures 2C* and 2D* :
 - a. Remove upper firewall above horizontal surface.
 - b. Remove entire rear fender inner panels and trunk floor.
 - c. Remove rocker panels and side panels (with door hinge posts).
 - d. Remove front fender inner panels 2" ahead of radiator mounts.
5. Move mounting brackets on radiator up 2" and re-mount.

The following again refers to all vehicles. We recommend at this point, that the chassis be cleaned off (steam, gunk etc.) and painted with a rust preventive paint.

If you are planning an engine "swap" the installation of the new engine should be done before mounting the body. See Section 9 for V-8 engine installation details.

4. MOUNTING THE JAMAICAN BODY

We recommend that, prior to mounting the JAMAICAN body on the chassis, a few preparatory steps be completed on the body while access to all areas is still possible. First, with the body upside down, trim the wheel opening flanges back to about 3/4" and sand smooth. Trim each rocker panel to an equal dimension from the door sill and sand smooth. Trim the tail section return as per Figure 4, and sand smooth. Then, with the body right side up again, cut the windshield and rear window openings to 3/4" from sill, cut out the door opening, leaving a 1/2" flange above the fender line (window opening, Figure 3E*) and at least 4" flange below the fender line (Figure 3G*). The lower flange will be trimmed later after the body is mounted to the chassis.

We suggest that the tail section be wired prior to mounting the body while the inside of that area is readily accessible. See Section 6 for wiring details. Be sure that the inner panels are correctly seated on the mounting surfaces of the chassis. Do not fasten down the body at this time, but proceed to the next step ---- mounting the doors.

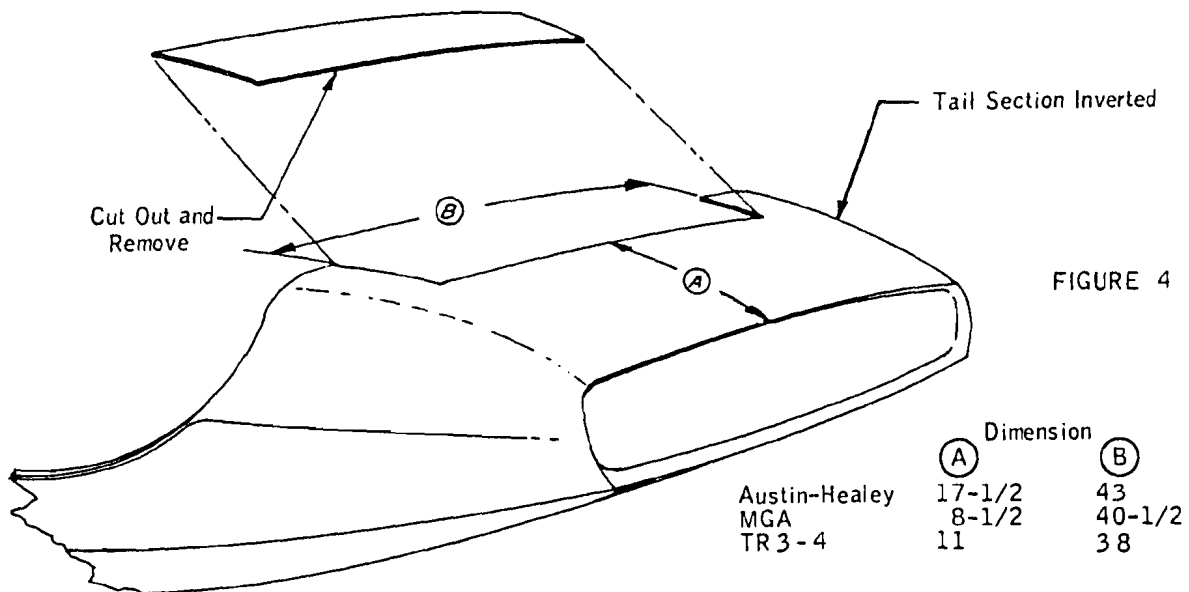

FIGURE 4

MOUNTING THE DOORS

Before the doors can be mounted, the following steps must be taken:

1. Trim the door edges back to the scribe line on the outside skin.
2. Cut the window slot in the top surface as per Figure 5.
3. Attach the door window trim as illustrated in Figure 3H*.

With these steps completed the doors may now be located in the body and temporarily held in place with masking tape. Particular attention should be given to the fit down the rear edge of the door and the area under the windshield post. Any mis-alignment along the bottom edge of the door may be corrected when bolting the body rocker panel (area beneath the door) to the chassis. Now locate the hinges as in Figure 3B* and mark the bolt hole locations on both the body and the doors. Remove the doors and drill out the holes, using a drill bit from 1/8" to 1/4" larger than the mounting bolts. The extra large holes will allow adjustment for a perfect fit. It is advisable to use a backing plate inside the doors for added strength when bolting the hinges to the doors. A plate 1/8" thick and the same shape as the surface of the hinge that bolts to the outside surface of the door should suffice. We have found that a nut-plate for the body-half of the hinges makes installation and adjustment much easier. These plates again may be fabricated of 1/8" steel plate (although 3/16" allows for more threads) approximately the shape of the hinge surface. Drill the bolt holes (undersize) and thread for the mounting bolts. If access to the back of the hinge-mounting surface in the body is not available, cut a 3" to 4" hole between the upper and lower hinges so that the nut plates may be inserted and secured. The doors may now be installed, with the hinges previously bolted to the doors.

The door latch mechanism, illustrated in Figure 3C*, should be mounted next. Since such a wide variety of latches are available, each with its own specific installation methods, an attempt will not be made here to describe the latch installation.

After the door installation has been completed, the main body section may be bolted to the chassis (remember to align the rocker panels with the doors when attaching these sections).

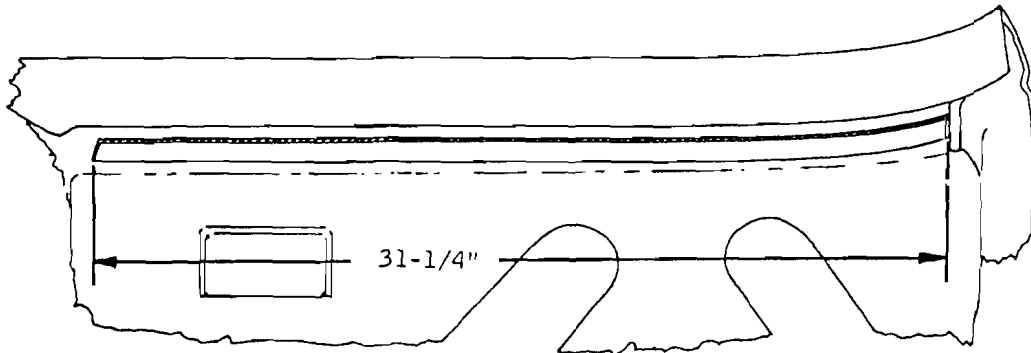
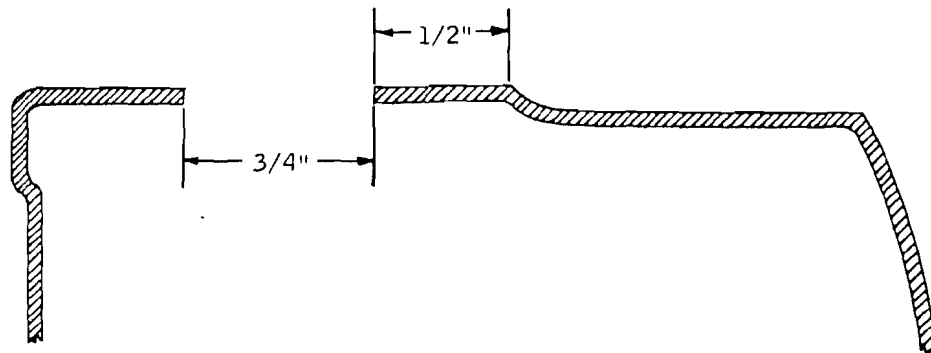
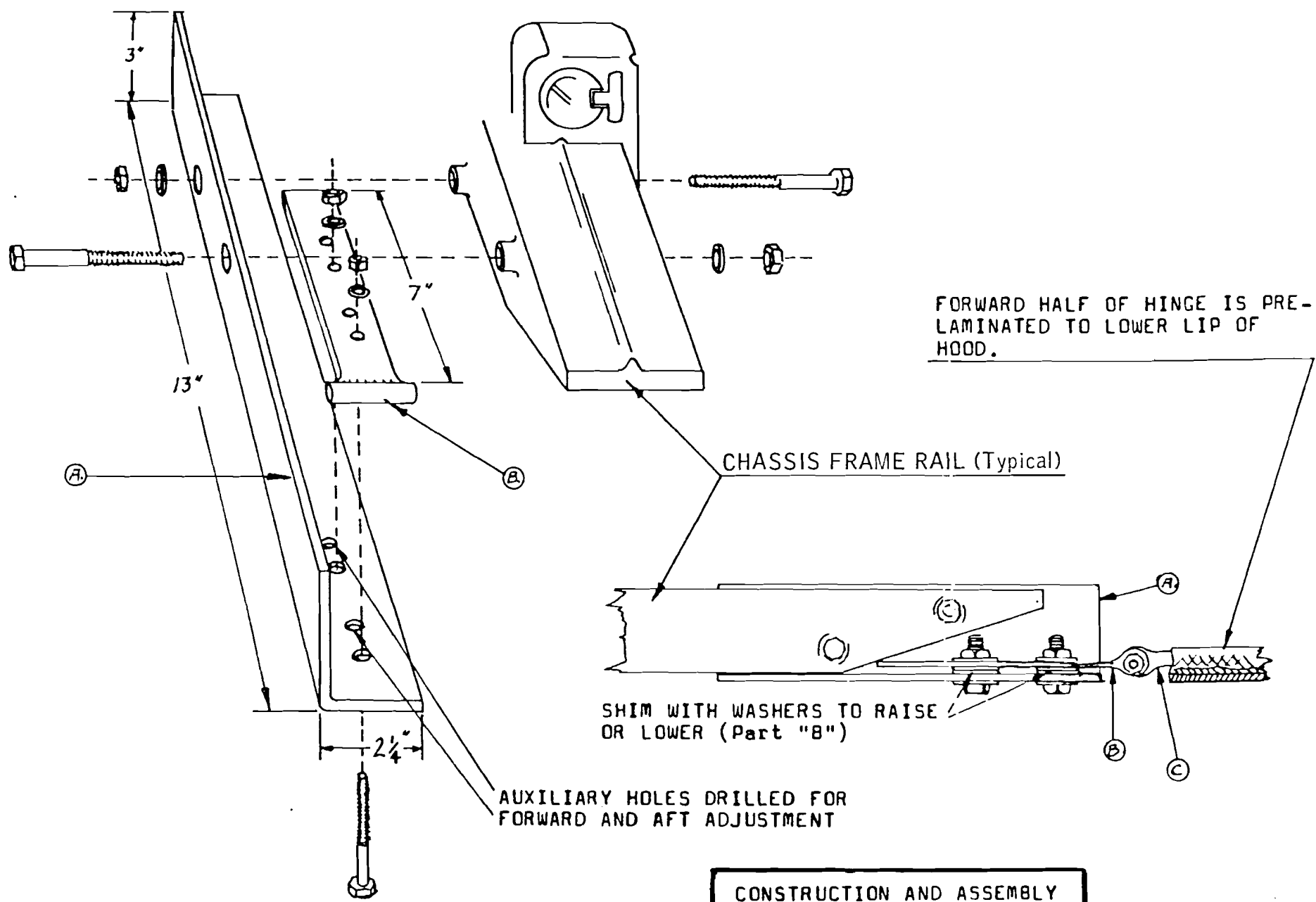

FIGURE 5



MOUNTING THE HOOD

Before placing the hood in position on the chassis, trim the rear edge (at cowl and doors) of the hood back to the scribe line and trim the wheel opening flanges as per the rear wheel openings. Place the hood on the cowl and block the front up until body crease lines up along the rear fenders, doors and front fenders. Mark the rocker panel overlap and trim for minimum gap. With the hood located in correct position make cardboard templates of the hinge brackets. These brackets should be bolted or welded to the main chassis rails. See Figure 6 for a typical installation. Be sure to use at least 1-1/2" steel angle or 3/16" steel strap for bracket material for strength.



FORWARD HALF OF HINGE IS PRE-LAMINATED TO LOWER LIP OF HOOD.

CHASSIS FRAME RAIL (Typical)

SHIM WITH WASHERS TO RAISE OR LOWER (Part "B")

AUXILIARY HOLES DRILLED FOR FORWARD AND AFT ADJUSTMENT

CONSTRUCTION AND ASSEMBLY
FRONT HOOD HINGE
FOR JAMAICAN

5. INSTALLING THE WINDSHIELD, REAR WINDOW AND DOOR WINDOWS

The JAMAICAN body is designed specifically to use the Chevrolet Stingray windshield and surrounding chrome trim. The windshield is supplied as part of the DELUXE kit. The chrome trim is available from your local Chevrolet dealer (see PARTS LIST for appropriate part numbers) if you wish to use it on your JAMAICAN.

The windshield is installed using the installation kit and silicone rubber sealant listed in Section 1, under Construction Materials. If chrome trim is to be used, twenty trim-retaining clips should be secured in place around the edge of the window opening before the glass is installed. Small, flat-head wood screws will suffice to hold the retainers securely. The material in the installation kit -- "butyl tape" (which has the appearance of a 3/8" diameter rope formed of a tar-like substance) -- is now pressed into place along the lip of the windshield opening. Then, the glass is laid in place in the opening over the tape and pressure is applied to compress the tape to about 50% of its original thickness. Now, the silicone rubber sealant is squeezed in the gap around the glass --- even on the retaining clips --- and the chrome trim is immediately installed by pressing it into the clips and sealant. Remove the excess sealant as soon as possible before it commences to set. DO NOT DISTURB THE GLASS FOR AT LEAST EIGHT HOURS AFTER INSTALLATION.

The rear window opening is designed expressly to accept the Porsche 912 rear window. The DELUXE KIT includes the rear window glass. The chrome trim is available from your local VW-Porsche dealer (see PARTS LIST for numbers). The rear window is installed in the same manner as the windshield. However, if chrome trim is to be used, the glass should be placed lightly on the installation material while the sealant is squeezed in the gap and on top edge of the glass. The chrome trim should be placed immediately around the glass and the entire assembly pressed into the installation material. Again, remove the excess sealant.

The JAMAICAN door window openings are designed to accept VW Karmann Ghia (1960-1963) door windows. The door inner panels are designed to accomodate the above mentioned windows and to support the roll-up mechanism --- slightly modified VW Karmann Ghia (see PARTS LIST for part numbers) --- for raising and lowering the side windows with a standard crank.

Figure 7 shows the guide-track and roll-up mechanism (for the left door). The bottom 1" of the guide-track must be cut off to fit in the JAMAICAN door and the two positioning pillars should be re-tapped to 5/16-18 to accept the 5/16-18 x 2-1/2" flat head machine screws required to fasten the track to the door inner panel. Drill and counter sink the holes in the door inner panel as illustrated in Figure 3A* for the guide-track screws. Insert the 5/16" flat head screws in the holes and run lock washers and nuts up the screws on the inside of the panel until they are near the panel. Insert the guide-track through the long slot in the panel and screw the flathead screws about 1/4" in the positioning pillars.

Re-tap the four tapped holes in the roll-up mechanism (Figure 7) to 1/4-20. Insert the mechanism through the large slot in the inner panel, insert the roller on the end of the arm into the cross-track on the guide track and bolt to the depressions in the inner panel with 1/4-20x3/4" hex head bolts.

Next, fit the rubber grommet in the glass holder, fit the two bolts (be sure to use the original VW bolts) in the inner holes. Insert the assembly through the slot in the top of the door and secure to the guide-track. The closed window may now be adjusted to fit the window opening by closing the door, cranking up the window and adjusting the guide-track positioning screws on the inner panel. When in the correct position tighten the nuts on these screws against the inner panel and adjust the limit adjustment (see Figure 7) so that the glass cannot be raised above this position.

6. WIRING AND INSTRUMENTS

This section of the instructions provides the ground-rules for completing the basic wiring of your JAMAICAN. In many instances, especially if the chassis was not acquired as a wrecked vehicle, the wiring harness should be intact and usable; some lengthening or shortening of particular wires may be necessary but, in general, the Austin Healey, MG or TR factory-installed wiring harnesses are adequate for the JAMAICAN.

In the cases where the original harness has been partially or totally destroyed or a radically different (from the original vehicle) electrical instrument/component layout (e.g., as a result of an "engine-swap") is desired, the following wiring guide should be helpful.

A basic wiring harness should provide for:

1. Starting
2. Ignition
3. Basic Instrumentation -- temperature, oil pressure (gauges or warning lights), fuel level, and battery/generator condition.
4. Interior and exterior lighting
5. Battery-charging and ground circuits
6. Accessory power and control -- windshield wipers, horn, heater fan, etc.

At this stage in construction, most items to be wired have been installed; e.g., the starter, the starter solenoid, ignition coil, oil pressure and water temperature senders, battery charging indicator (voltage regulator) and fuel level sender unit are all available for wiring. Lights, however, are yet to be installed.

TAIL LIGHTS

As was mentioned in Section 4, the rear body section should be wired before mounting with plugs for ease of installation. The two common wiring techniques covering all chassis applications are illustrated in Figures 8a,b,c. If your chassis had a single tail light bulb per side, an eight-contact Lucas relay may be found under the hood and Figure 8b should be used. For a dual tail light bulb installation (no relay), use Figure 8c. We recommend that the original turn signal/brake light configuration be retained to simplify the wiring task. In either case, locate and secure the light sockets to the body and wire as per the applicable diagram. Drill holes through the inner panels and connect the male end of 4-prong plug or plugs near the center of the rear body panel (on the inside). Be careful to note the function of each wire being attached to a plug-pin inasmuch as these functions must carry - through to the plugs wired on the chassis.

HEADLIGHTS AND PARKING LIGHTS

Headlight brackets should be fabricated as shown in Figure 3D* and secured to the headlight bucket backing plate. Cut a 7-1/8" diameter hole in the center of the headlight-tunnel and bolt the assembly in place. Park/turn lights can be installed on sheet-metal brackets located in the grille opening. Remember, when mounting the lights -- or for that matter, any electrical component --- in fiberglass, unlike steel bodies, that a **SEPARATE GROUND WIRE MUST BE INCORPORATED IN THE WIRING HARNESS** in order to complete all circuits back to the battery "ground" terminal.

INSTRUMENT PANEL WIRING

Your JAMAICAN body is delivered to you with a fiberglass dashboard already laminated in place. The dash is designed to utilize a centralized instrument/control cluster -- this cluster is the hub of the wiring harness and should be carefully planned. The basic instrument/control requirements are satisfied by the following indicators, switches, etc.:

Controls --

1. Key-operated ignition switch
2. Headlight/parking light switch
3. Headlight dimmer switch
4. Accessory control switches, as required.

Indicators --

1. Fuel level gauge
2. Water temperature gauge or light
3. Oil pressure gauge or light
4. Ammeter or charge/discharge warning light
5. Headlight high-beam "on" indicating light
6. Speedometer (non-electrical).

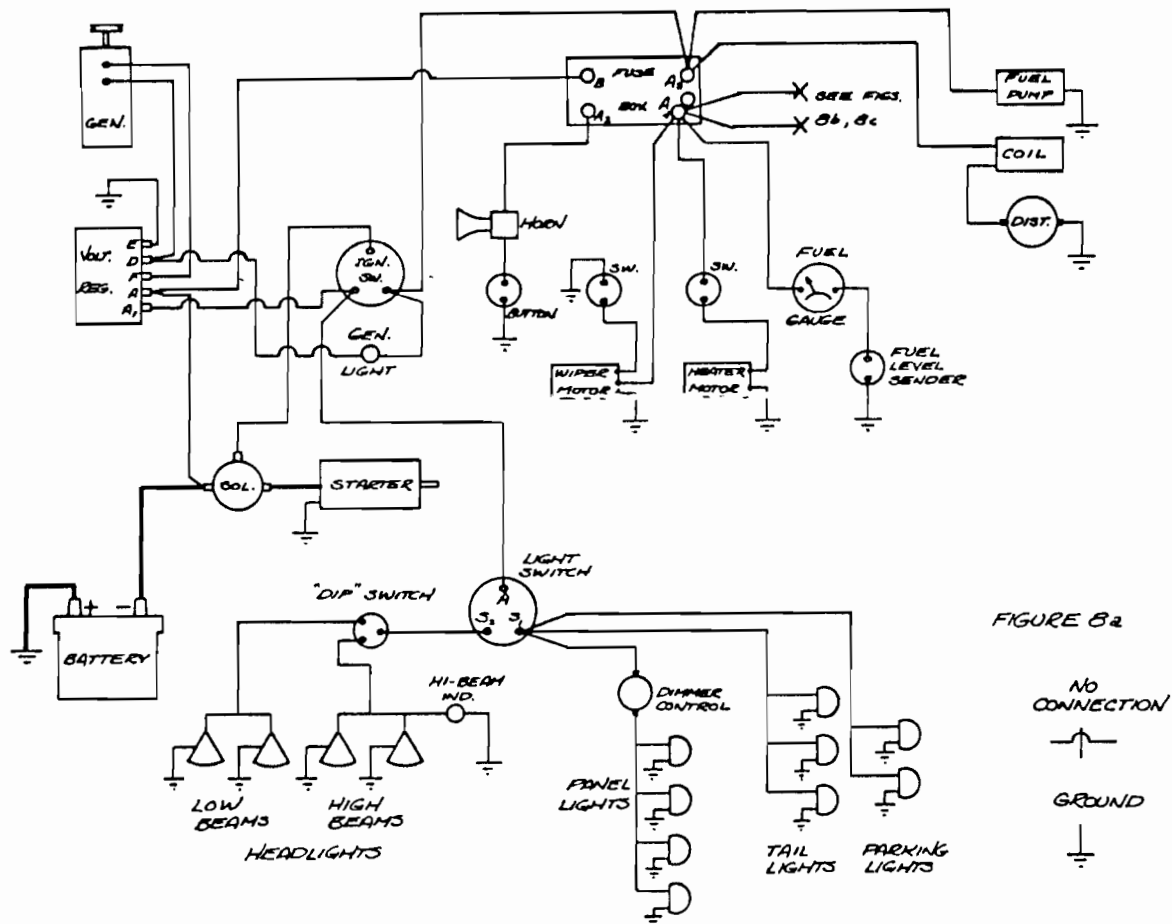
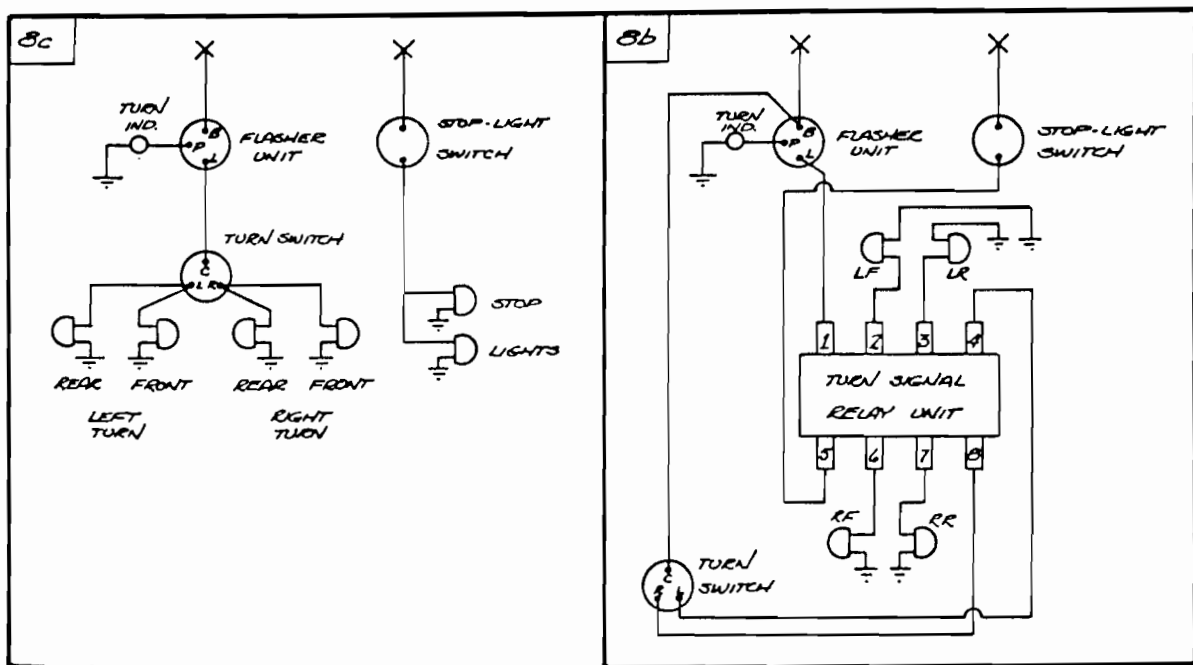

FIGURE 82



CHASSIS WIRING

The wiring harness is divided in two major pieces -- hub-to-front and hub-to-rear. The hub-to-front wires are routed from the hub (instrument/control cluster) forward to the firewall and then through a grommetted hole in the firewall above and to the right of the steering column. Engine instrumentation, ignition and starter solenoid leads end at a terminal block mounted centrally at the top of the engine side of the firewall. Lighting leads continue forward along the frame rail and terminate in female connectors which mate with the male connector serving to terminate the in-the-hood wiring. Connection is made at a point on the frame ahead of the front wheel centerline.

NOTE: Provide sufficient wire for the male connector to reach the female connector even with the hood fully open.

The hub-to-rear harness is routed from the hub forward to the firewall, along the firewall to the righthand wheel-well, down the firewall to the floor, around the well, under the door-jamb to the rear wheel-well, over the well to the rear of the body.

THE HUB-TO-REAR HARNESS CONTAINS:

1. Hub to brake lights -- one #10 wire in the harness to the RH light, then across the rear to the LH light. (DON'T FORGET TO GROUND THE LIGHTS TO THE CHASSIS!)
2. Hub to tail lights -- one #10 wire routed the same as the brake lights.
3. Fuel gauge to fuel-level sender -- one #16 wire to the tank sender terminal.
4. If the battery is rear-mounted, the ammeter-to-battery connection is made in the following manner. Connect the battery "hot-side" to the starter solenoid via 12-volt battery cable run adjacent to a fore-and-aft frame member. Connect the ammeter to the same solenoid terminal via #10 wire run in the hub-to-front harness.

THE HUB-TO-FRONT HARNESS CONTAINS:

1. The hub to brake light switch and return -- two #10 wires to the firewall terminal strip (from the terminal, two #10 wires go to the brake light switch mounted on the brake master cylinder or in the forward brake lines depending on the vehicle.) These wires carry battery "hot-side" to the pressure switch and back to the hub for distribution to the rear.
2. Temperature and pressure indicators to appropriate engine mounted senders -- two #16 wires to the terminal block -- from the terminal block two #16 wires to the senders.
3. Ammeter to voltage regulator -- one #10 wire to the terminal block -- one #10 wire from the block to the "armature" terminal on the regulator.
4. Headlight switch to parking lights -- one #10 wire from the hub to the six-pin female connector.
5. Headlight switch/dimmer switch (dash mounted) to low beams -- one #10 wire routed as parking light wire.
6. Headlight switch/dimmer switch (dash mounted) to high beams -- same as low beam.
7. Ignition switch to starter solenoid -- one #10 wire to the terminal block -- one #10 wire from the block down the firewall to the solenoid.
8. Ignition switch to starter solenoid -- one #10 wire to the terminal block -- one #16 wire from the block to the coil "BAT.", "SW.", etc. terminal.
9. If the battery is front-mounted, i.e., under the hood, an ammeter-to-battery connection is required in the hub-to-front harness. Use #10 wire to the terminal block and #10 wire from the block to the battery "hot-side" (U.S. cars use the "+" battery terminal as hot and "-" terminal for ground. British cars with LUCAS ignition and electrical system use the reverse, i.e., "-" is hot.)

The items of instrumentation mentioned above may be ordered from your local Stewart-Warner dealer or directly from Fiberfab. See the parts list for the recommended set Stewart-Warner gauges and senders.

Some "unharnessed" connections are required in the engine compartment. They include:

1. Ignition coil "DIST", etc. terminal to the distributor -- use #16 wire.
2. Generator/alternator field to the voltage regulator -- use #16 wire.
3. Generator/alternator armature to the voltage regulator -- use #10 wire.
4. Battery "hot-side" to the starter solenoid -- use 12-volt battery-cable.
5. Battery "ground-side" to ground (some point on the frame close to the battery) -- use 12-volt battery-cable.

The preceding material should serve as a guide to the basic wiring of your JAMAICAN. Additional items such as horns, direction indicators, tachometers, etc., can be added at your discretion. In general, all additional wiring can be simply added into the hub-to-front or hub-to-rear harness without incurring any special routing problems.

ROLL-UP WINDOW MECHANISM PARTS

Identification by Volkswagen Part Numbers

	<u>LEFT DOOR</u>	<u>RIGHT DOOR</u>
REGULATOR	141 837 501B	141 837 502B
TRACK ASSEMBLY	141 837 551B	141 837 552B
GLASS HOLDER	141 837 571A	141 837 571A
WINDOW GLASS GROMMET	141 837 565A	141 837 565A

FIGURE 7

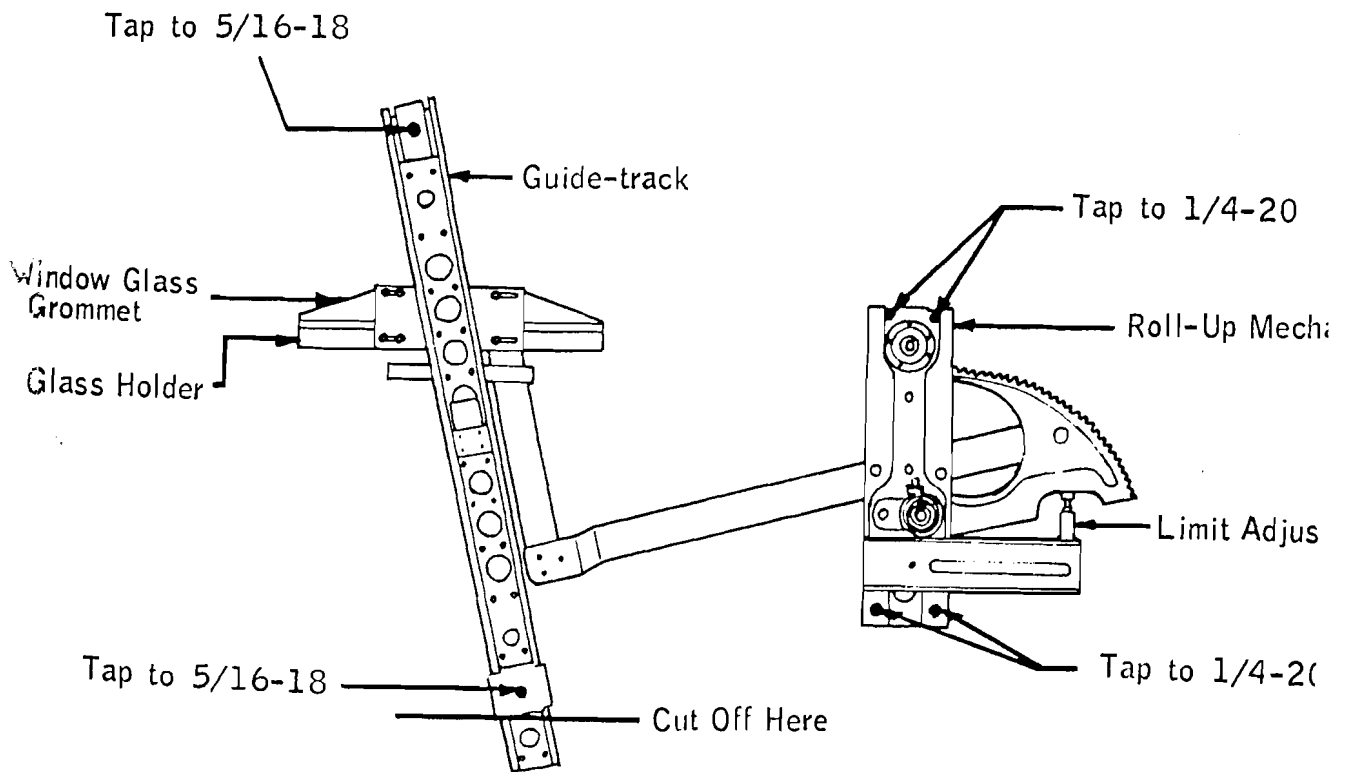

7. UPHOLSTERY -- INTERIOR FINISHING

The upholstery of your JAMAICAN is purely a matter of personal taste. You can be as simple or as elaborate as you desire -- austere for the road machine, buff or "posh" for the grand touring enthusiast.

At the factory, we use, of course, the JAMAICAN upholstery kit (available at extra cost). The standard upholstery kit consists, in part, of automotive-grade carpet cut to fit the floor, firewall and headliner surfaces and bound with plastic, sewn binding to prevent ravelling. The carpeting is affixed with 3M (Copyright, Minnesota Mining and Manufacturing) Trim Adhesive dispensed from a spray can.

Wood blocks should also be glued into the windshield pillars to provide attachment points for the upholstered pillar panels -- again easily constructed of vinyl over cardboard and foam rubber.

If you have access to a commercial sewing machine you can make your own carpeting, rugs, etc. Use heavy paper to make a pattern of the interior of the car. Transfer this pattern to the carpet (making sure it is not upside-down) and cut. Sew on the binding. Spray the surfaces to be covered with trim adhesive. Install the upholstery. Use the same "paper pattern" technique to develop the door panels, windshield pillar panel, etc., shapes.

In the area behind the seats (under the rear window) plywood paneling can be inserted between the rear wheel-wells and over the gas tank and spare tire compartment. Cut a pattern from a piece of corrugated cardboard and transfer this to 1/4" plywood -- use marine plywood and varnish well before installing.

The plywood interior surface can be painted to match the upholstery or covered with carpet like the floor and headliner. Chrome skid strips can be tacked over the carpet, running fore and aft at a 4" to 5" spacing -- these strips allow luggage to be easily placed behind the seats without scuffing the carpet.

Upholstered door panels, available as part of the standard upholstery kit are attached to the door inner panels with plated phillips head sheet metal screws with finishing washers.

As a finishing touch, a courtesy light can be installed overhead on the vehicle centerline just forward of the rear window. Wiring is routed up a windshield post and under the headliner material. The operating switches are mounted facing up through the door jamb at the very front of the jamb, out of the way of entering and exiting feet.

The stock Austin Healey, MG**, or Triumph heating system can be utilized with the JAMAICAN body. New ducts must be cut through the top of the dash to allow defroster air to reach the windshield.

** See chassis preparation for minor modification to MGA heater box.

8. EXTERIOR FINISH

The most important item in the area of exterior finish is, of course, the painting. Fiberglass is most compatible with acrylic lacquers. Lacquers, also, are the easiest and most trouble-free in their application. They can even be applied in a slightly dusty environment -- the dust and spraying imperfections can be rubbed-out subsequently. Just follow the paint instructions and don't try spraying on cold and/or damp days.

About body surface preparation -- most fiberglass bodies have slight imperfections such as pin holes or moldmarks. Often they will pick up a few scratches during shipment. It is virtually impossible to avoid this. Body putty and sand paper should take care of any body finish problems you might have.

We are proud of the finished surface of our bodies. We use special care and materials around the edges of the body surface to prevent chips. One of our own AZTECS, with over 50,000 miles on it, does not have one body crack in it. It still has its original paint job, too!

Your JAMAICAN body will have a color when you receive it. In most instances, this color will be black. This is not the finished color. This is a special gelcoat your body has been given to achieve a better surface.

Before you paint your JAMAICAN the entire body should be lightly sanded with #400 sandpaper. The body is sanded in order to "scuff up" the surface which is too stick to hold paint. Remember to go lightly! Then the body should be washed off and wiped with Prepsol or some other paint preparation liquid to eliminate any oil or dirt. The body is now ready for primer and paint.

Other Items of Exterior Finish Are:

WINDSHIELD WIPERS -- The Austin Healey, MG and TR windshield wiper actuator systems are almost identical, one to another. They consist of a 12-volt motor driving a crank which pulls and pushes a cable inside a tube. The wiper pivots are mounted on the tube and engage the back and forth motion of the cable.

Installation in the JAMAICAN is simply a matter of mounting the pivots in two holes drilled through the cowl as shown in Figure 3F*. The motor is brought to a convenient mounting location by gently bending the cable-bearing tube until the motor contacts the desired mounting surface.

WEATHERSTRIPPING -- The only place the JAMAICAN may require weatherstripping is around the hood and doors. We suggest, for the hood, using a thin strip (3/4" wide) of adhesive-backed foam rubber. Typical stripping material is found, for example, in the Sears catalog bearing #28A7226. Apply the stripping after painting. The door weather strip (Figure 3G*) is a combination windlace and weatherstrip, available as a standard item with the upholstery kit, and is installed by simply slipping over the prepared fiberglass flanges.

9. V-8 POWER OPTION

Soon after World War II, the sports car business began to flourish with the introduction of the MG-TC -- and soon after its introduction certain owners inevitably wanted more "go". Some enthusiasts went the supercharger/super-tuning route largely with disastrous results -- the notable exception was the magnificent (and very expensive) "old 88", and MG-TC fitted with an INTERMECCANICA blower, intercooler and special body.

Other builders resorted to the "engine swap". The MG engine was replaced by the venerable Ford V-8/60. Substituting engines -- if suitable constraints on engine size and power were applied -- proved far more satisfactory than to "hop-up" the stock engine.

Today the V-8/60 has long been superseded by the Chevrolet 283 cu. in. V-8 and more recently by the Ford 289 cu. in. V-8 "Fairlane engine".

Any of the vehicles suitable for use with a JAMAICAN body are also suitable for either of these V-8's. The Austin Healey 3000 series chassis is probably the best to use if engine outputs exceeding 175 BHP are being considered. We would recommend, in any case, that the horsepower not exceed 250 BHP unless the entire frame, drive-line and suspension are reworked to safely contain the higher power.

The best time during the JAMAICAN construction to perform the engine swap is, obviously, before the body is mounted. In the course of preparing the chassis, remove the original engine, the engine mounts and the transmission and its mounts. (Note: The stock transmission can be retained for low power -- under 150 BHP -- installations and if a suitable engine-to-gearbox adapter is available).

The "new" V-8 and gearbox (we used a Warner T-10 box and a Ford 289 for our Healey-JAMAICAN-Ford, and a Buick Aluminum V-8 for our MGA-JAMAICAN-Buick*) are lowered into the engine compartment and blocked in position. New engine and gearbox mounts are now fabricated, fitted to the engine-gearbox in place, and welded to the frame.

Once the engine and gearbox are permanently installed, the drive-shaft can be shortened by cutting and welding (make certain it is straight after welding) and the HURST-shifter can be installed.

A high capacity radiator, such as the Harrison aluminum radiator for Corvette, should be installed. A surge tank should be mounted with the filler opening above the level of the cylinder heads.

No significant modification in wiring should be required -- the ignition system remains 12-volt. Only the oil pressure and water temperature sending units may be different.

Several notes in closing -- a good reference for HURST parts, special engine/gear box mounts, instruments, etc., is the "Honest Charley" catalog available from:

HONEST CHARLEY SPEED SHOP
Honest Street at North Hiway II
Chattanooga, Tennessee 37421

When acquiring a wrecked vehicle for a JAMAICAN and an engine swap is contemplated avoid cars with wire wheels -- choose the disc wheels for strength and durability.

PLEASE FEEL FREE TO CONSULT US! When you are building your JAMAICAN, if you encounter some problems outside the scope of these instructions or are having trouble obtaining any of the materials you need, do not hesitate to contact us. We will be pleased to assist you in any way we can.

* For details concerning the V-8 installation, contact our factory.

10. THE JAMAICAN-VOLKSWAGEN

The JAMAICAN-VOLKSWAGEN conversion instructions are set apart from the balance of the material in this manual because of the large number of unique procedures involved in completing this rear-engined variation. Sections 1, 2 and 4 through 8 are applicable to your VW-based project. Section 3, however, is superceded by the following material.

REMOVING THE VOLKSWAGEN BODY

Before you start to unbolt the body, remove the front and rear seats, disconnect and remove the battery and drain the gas tank. Next, remove the left front tire/wheel in order to unbolt the steering shaft by removing two bolts from the steering shaft universal joint. Now disconnect the horn wire.

Now disconnect the manual choke cable or the wire from the electrically operated choke. Disconnect the wires (to the coil and voltage regulator) and acceleration cable from the engine.

Remove the choke from the dashboard (no dashboard control exists for the electrically/thermostatically operated choke) and pull the cable through to remove it. Disconnect the gas lines to the gas tank and remove the tank by unbolting (see Figure 9) and lifting it up and out. Don't forget the reserve fuel switch-over valve in the cockpit.

You are now ready to unbolt the body. First, remove the bolts located along the outside edges of the underside of the floorpan (see Figure 9). Next, remove the several bolts remaining at the front underside of the floorpan -- just inside the front wheel-wells.

Remove the four bolts exposed when the rear seat was taken out. Finally, remove the rear tires/wheels and unbolt the body bolts in the wheel-wells. **SAVE THESE BOLTS!**

The body should now be free to be lifted off via block and tackle, chain-hoist, or yourself and "several strong and willing helpers." **CAUTION: The Volkswagen body is extremely heavy!** It is because of this weight loss, incidently, that you may expect better-than-Volkswagen performance in your completed JAMAICAN-VW.

Care should be exercised when lifting off the Volkswagen body in order to preserve the body-to-floorpan rubber seal. It can be used to "weatherstrip" your new JAMAICAN body.

It is advisable to save all the undamaged parts such as the steering column and wheel, gas tank, instruments, etc., inasmuch as these items can be used to complete your JAMAICAN.

INSTALLING THE FRAME RAILS

The frame rails are installed next. Remove the dust covers (4 bolts each) from over the ends of the rear torsion bars (covers on early chassis fit around the end of the torsion bar leaving it exposed, while covers on late chassis completely cover the end of the bar).

Modify the dust cover as shown in Figure 10 and replace them on the floorpan with the upper two bolts (don't forget to put the rubber "doughnuts" back under the covers.) Bolt the end-plate of the frame rails to the floorpan over the dust covers using the bottom two dust cover retaining bolts -- leave the bolts loose. Lift the front end of the frame rail and secure it under the lower, front torsion bar housing (tube) using the U-bolts provided with the frame rails. Position the U-bolts about 13 inches either side of the floorpan centerline -- tighten all bolts. Secure the edge of the floorpan to the rails by drilling through the 'pan into the 'rails and fastening with large sheet-metal screws.

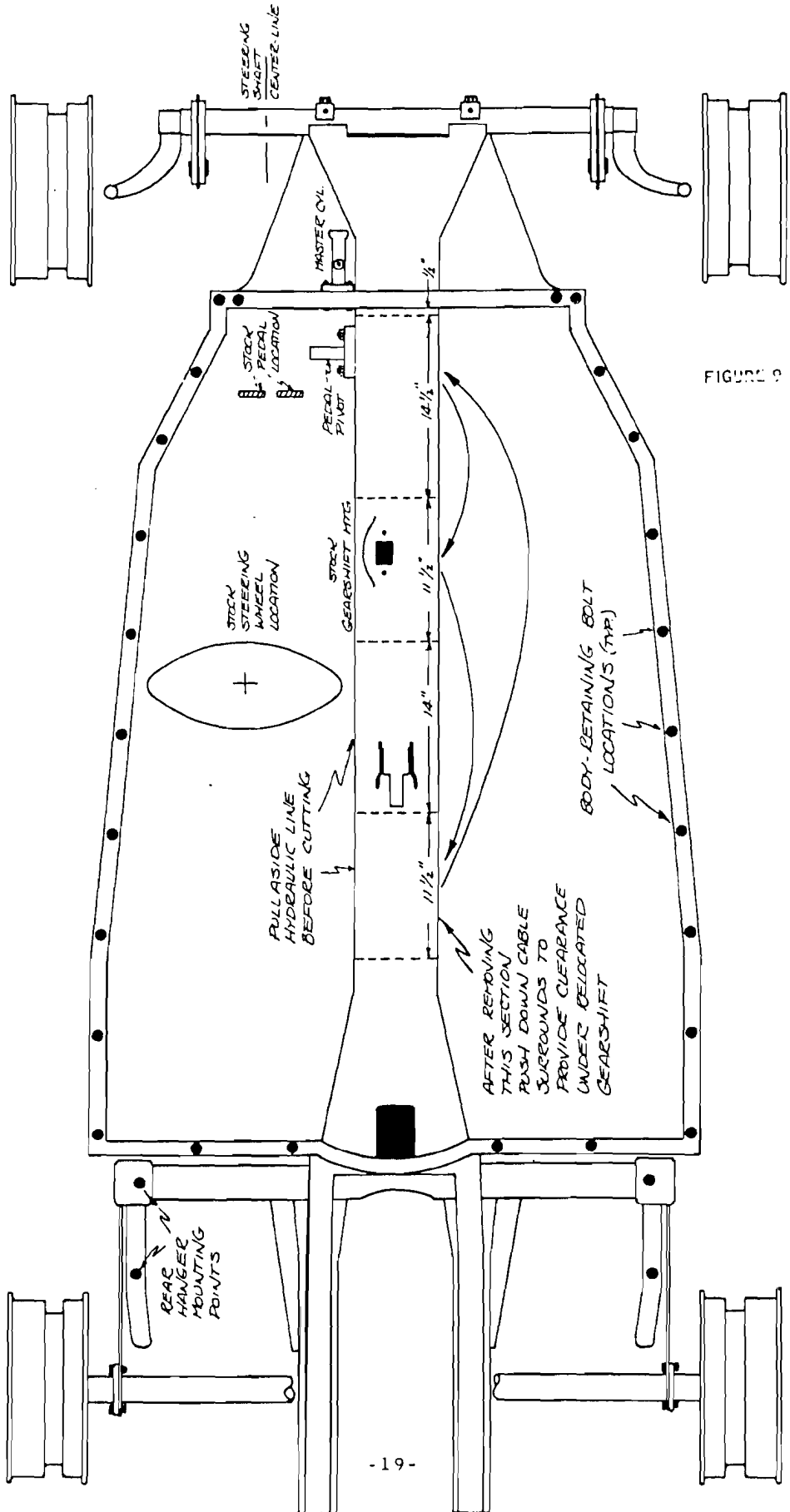

FIGURE 2

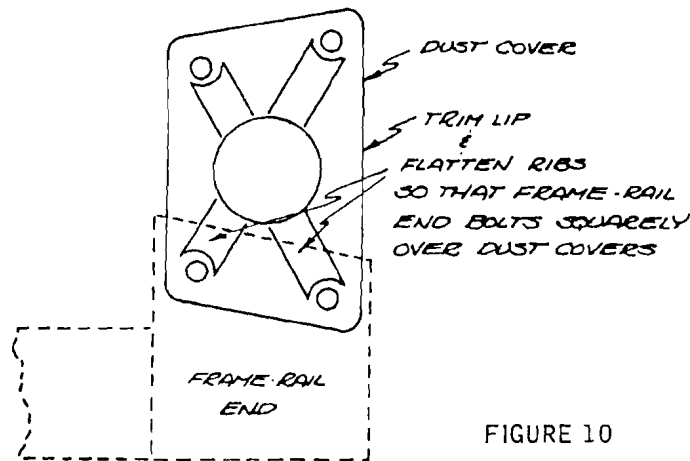

FIGURE 10

REPOSITIONING THE COCKPIT CONTROLS

With the floorpan supported by the frame rails, the central tunnel of the floorpan can be cut and "rearranged" in order to relocate the pedals and gearshift. Referring to Figure 9 -- three full sections are cut from the tunnel and replaced as shown. The cutting can be accomplished using a sabre-saw or an oxy-acetylene cutter. Cuts should be made along the side of the tunnel as close to the floor as possible -- cuts up the sides should be perpendicular to the floor. Care should be taken to cut only the tunnel, not the tubes and cables running within the tunnel.

Figure 11 shows the reconfigured VW 'pan ready for the JAMAICAN body. For the pedals to operate in their "new" position the clutch and accelerator cables must be shortened by cutting-off 14 1/2 inches and reswaging the end fittings to the cut ends. The tubing surrounding the accelerator cable is pushed back inside the tunnel and cut-off flush at the point it exists the rear of the tunnel. The pedal pivot support tab is re-bolted to the pan through a new hole drilled in the 'pan after the pivot is securely in its new position.

Repositioning the steering column and wheel is accomplished by lowering (reducing the angle between the 'pan and the column) and lengthening the steering column/shaft. The required lowering is quite simple. The VW steering box is only clamped on the upper front torsion bar housing. It can be rotated on the housing just by loosening the clamps. With the clamps loosened, the steering box should be rotated such that the steering linkage just clears the "hump" in the center of the floorpan when the wheels are turned from lock-to-lock. (Lowering the steering box alters the toe-in adjustment of the steering geometry. Proper toe-in is reestablished by adjusting the tie-rods until the fronts of the front tires are about 1/8" closer together than the backs -- refer to Figure 12. Make sure the adjustment is divided equally between the tie-rods).

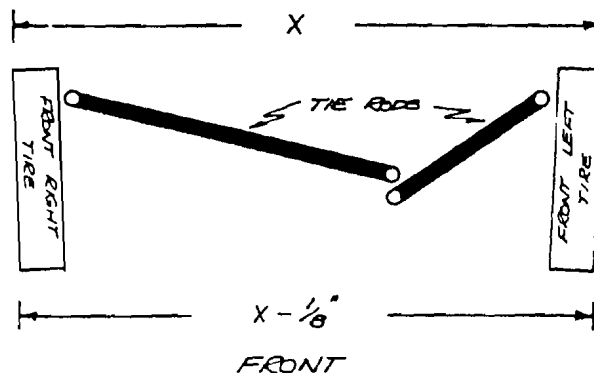

AFTER ROTATING STEERING BOX SHORTEN TIE RODS UNTIL 1/8" TOE-IN IS ACHIEVED

FIGURE 12

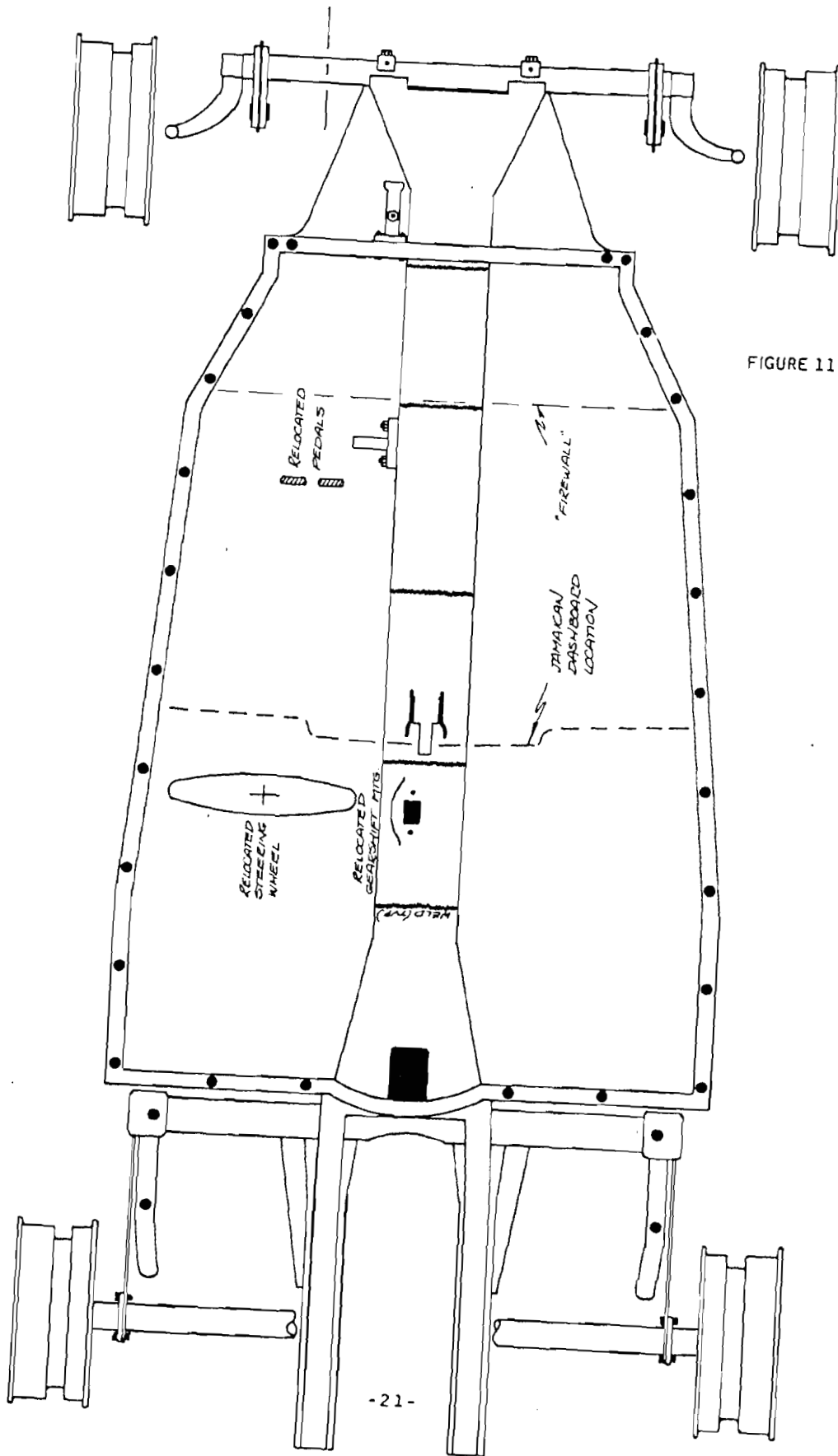
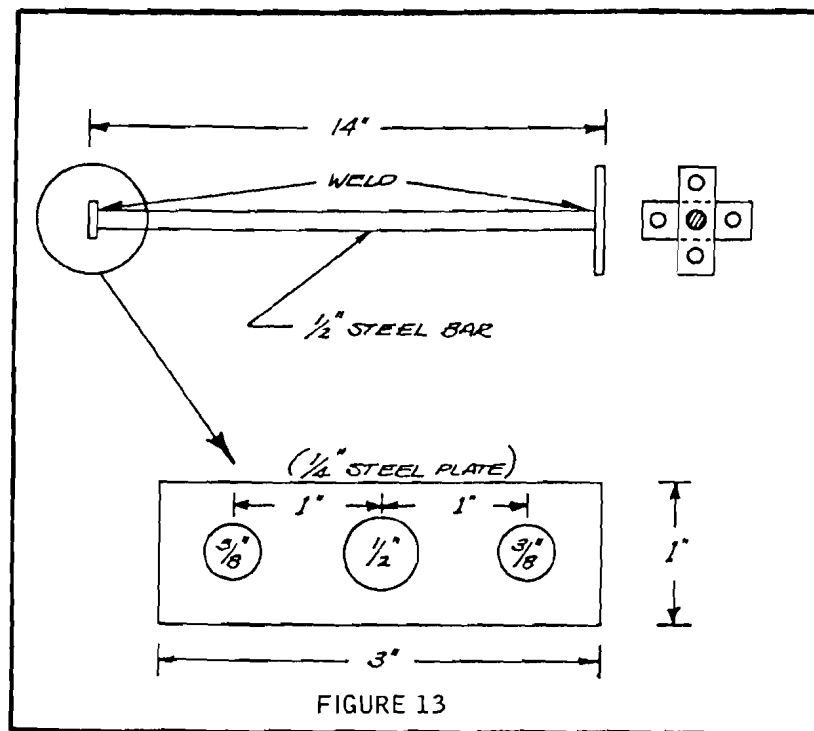

FIGURE 11

A simple method of lengthening the steering shaft the required 14 inches is to insert the extension, shown in Figure 13, between the steering box and the steering shaft. The order of assembly of steering components in a stock VW is: steering box, flexible rubber disc, "T"-flange, steering shaft. The revised order of assembly for the JAMAICAN/VW is: steering box, flexible rubber disc, 14" extension, flexible rubber disc, "T"-flange, steering shaft.



MOUNTING THE REAR HANGERS

The final step in preparing the floorpan is to mount the rear hangers for the tail section of the GT-12 body. Figure 14 shows both hangers in place on the mounts formerly used to secure the Volkswagen body. When the fiberglass tail section is installed, shims (washers) may have to be placed under the front, rear or both hanger-mounting feet (see Figure 14) to precisely align the tail section with the main body section.

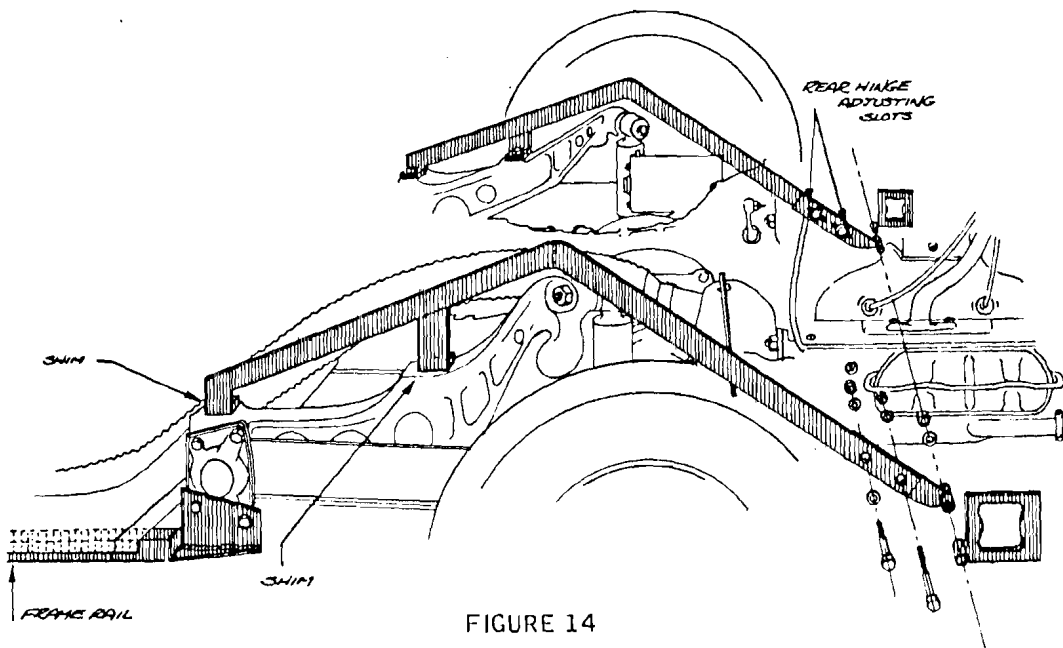
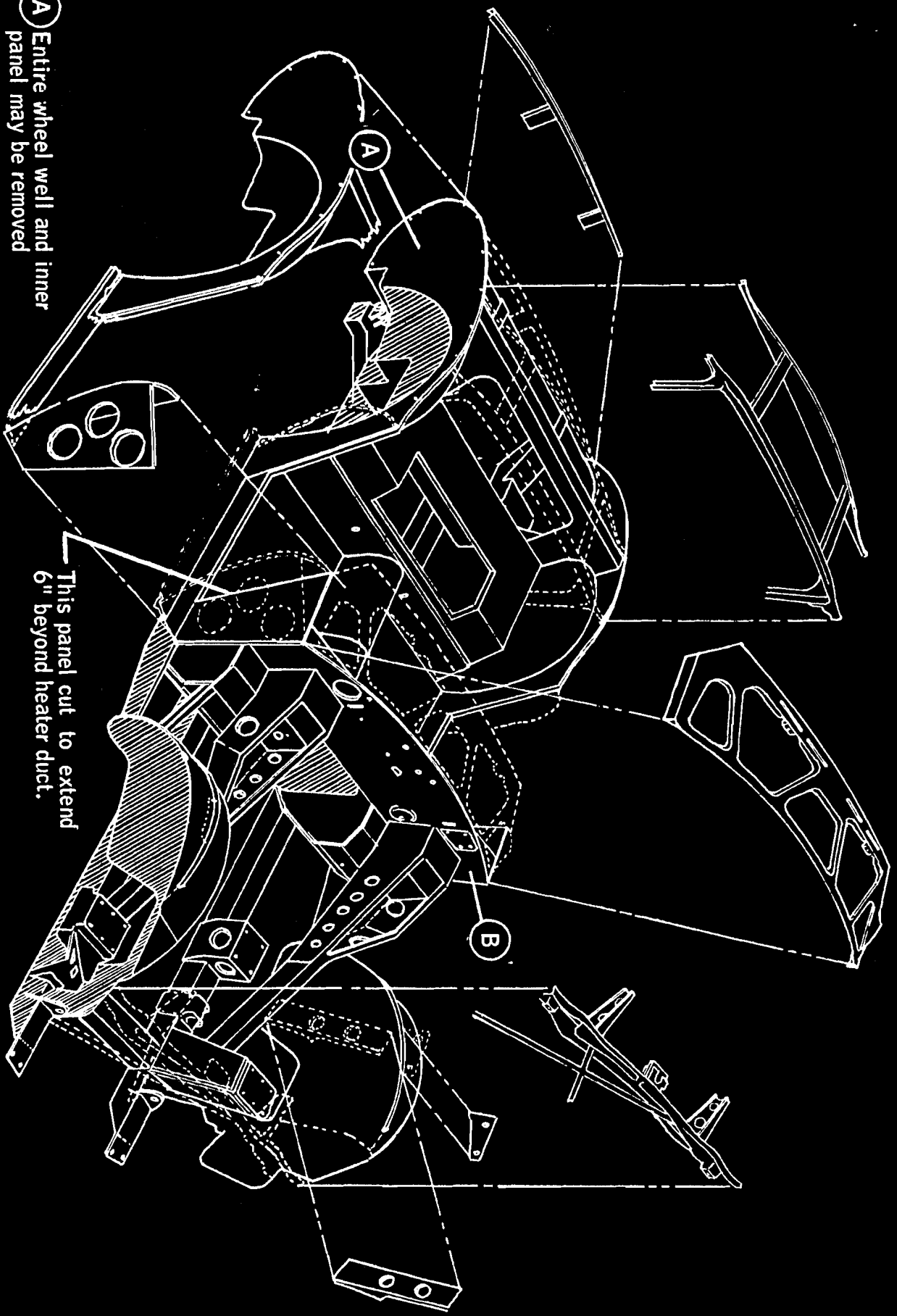

FIGURE 14

FIGURE 2 A: AUSTIN HEALEY



A Entire wheel well and inner panel may be removed

B Trim 2" off top of firewall

This panel cut to extend 6" beyond heater duct.

